

# Istruzioni di montaggio per zanzariera, scorrevole senza guide a pavimento.

## Tipologia apertura 1 a 2 ante.

### distinta

- 1 Binario con compensatore.
- 2 battute laterali con compensatore.
- 1 anta con calamita e finta calamita.
- 1 anta con calamita e spazzolino.
- 2 manigliette.
- 4 tappi copri vite per manigliette.
- 6 tappi copri foro.
- 4 blocchetti antisbloccaggio.
- 1 piastrina pavimento.
- 4 viti autoforanti con impronta a croce 3,9x32, Zincate.

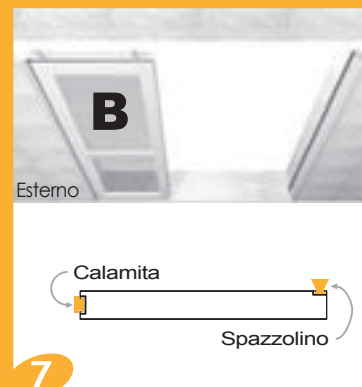
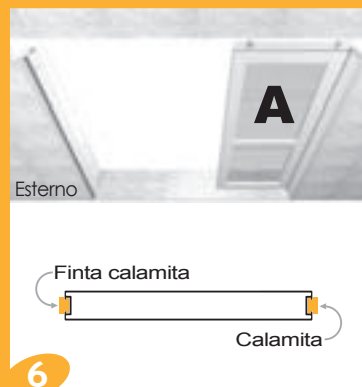
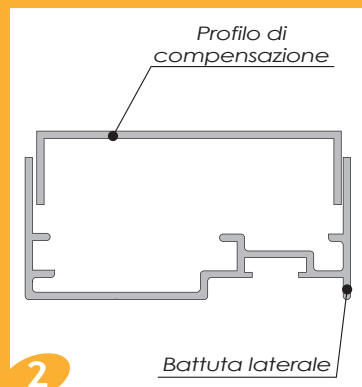
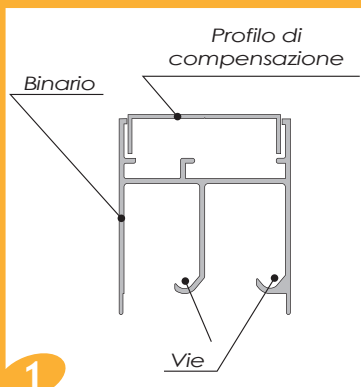

Avvitare fino ad ottenere una discreta stabilità della struttura

17



Forare e avvitare  1



18

Separare gli antisbloccaggio in modo che possano ospitare nel mezzo un'anta

19

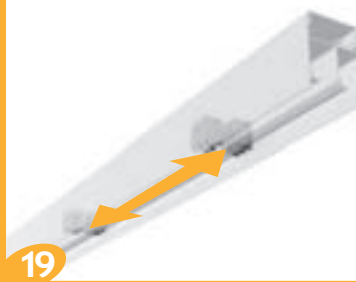

Inserire l'anta **A** nella via interna del Binario

20



21



Inserire la Piastrina pavimento

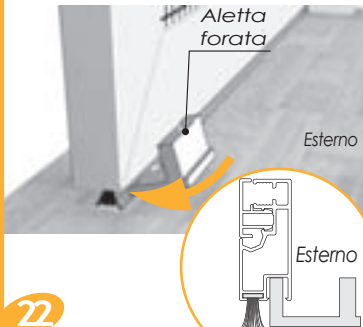

22

Agganciare l'anta al magnete della Battuta laterale

23



Far scivolare la Piastrina pavimento fino all'estremità dell'anta

24

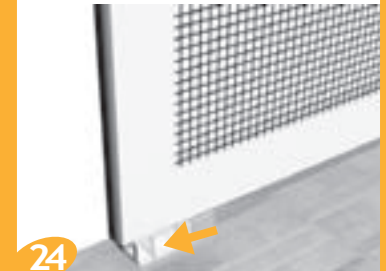

Segnare il punto per il foro

25



Forare  2

26



Avvitare  2

27



Alzare leggermente l'anta per inserirla nella Piastrina pavimento

28



Allentare i Grani compensatori per facilitare l'aggancio dell'anta **B**

29



Inserire l'anta **B** nella via esterna

30



Alzare leggermente l'anta per inserirla nella Piastrina pavimento fissata a terra

31



Regolare i Grani compensatori fino a che ogni anta abbia lo spazzolino appoggiato a terra

32



Forare  1

33



Avvitare  1

34



Inserire due antisbloccaggio per ogni anta, incastrandoli nell'aletta superiore

35



L'azienda si riserva di apportare modifiche senza preavviso

# Istruzioni di montaggio per zanzariera, scorrevole senza guide a pavimento.

## Tipologia apertura 2 a 2 ante.

distinta

- 1 Binario con compensatore.
- 2 battute laterali con compensatore.
- 1 anta con calamita e finta calamita.
- 1 anta con calamita e spazzolino.
- 2 maniglie.
- 4 tappi copri vite per maniglie.
- 6 tappi copri foro.
- 4 blocchetti antisbloccaggio.
- 1 piastrina pavimento.
- 4 viti autoforanti con impronta a croce 3,9x32, Zincate.

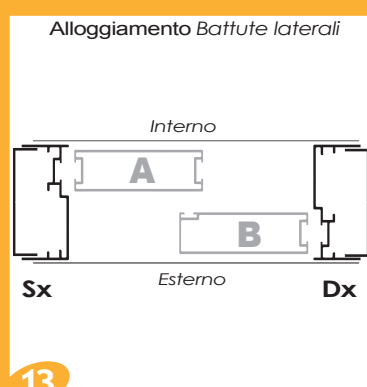
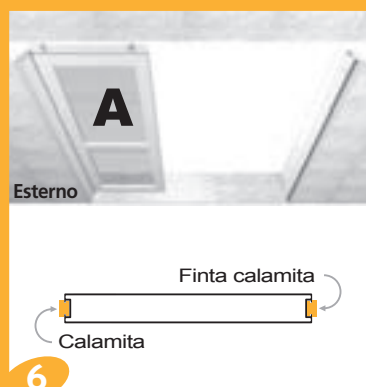
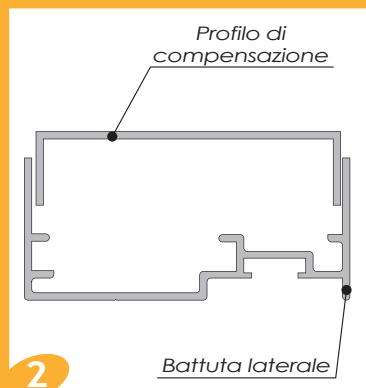
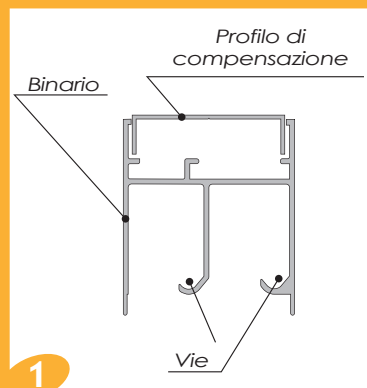



Avvitare fino ad ottenere una discreta stabilità della struttura



Forare e avvitare \*1



Separare gli *antisbloccaggio* in modo che possano ospitare nel mezzo un'anta

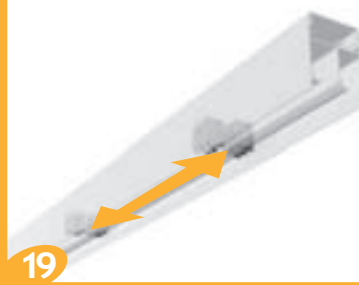

Inserire l'anta **A** nella *via interna* del *Binario*



Inserire la *Piastrina pavimento*

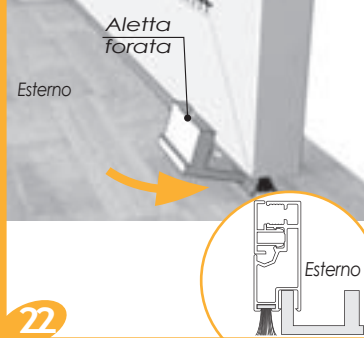

Agganciare l'anta al magnete della *Battuta laterale*



Far scivolare la *Piastrina pavimento* fino all'estremità dell'anta

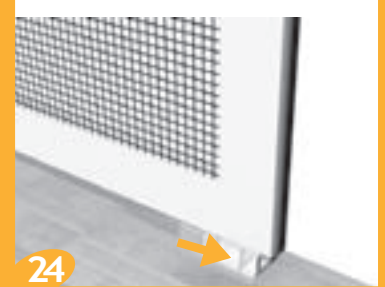

Segnare il punto per il foro



Forare \*2



Avvitare \*2



Alzare leggermente l'anta per inserirla nella *Piastrina pavimento*



Allentare i *Grani compensatori* per facilitare l'aggancio dell'anta **B**



Inserire l'anta **B** nella *via esterna*



Alzare leggermente l'anta per inserirla nella *Piastrina pavimento* fissata a terra



Regolare i *Grani compensatori* fino a che ogni anta abbia lo spazzolino appoggiato a terra



Forare \*1



Avvitare \*1



Inserire due *antisbloccaggio* per ogni anta, incastrandoli nell'alea superiore



L'azienda si riserva di apportare modifiche senza preavviso

# Istruzioni di montaggio per zanzariera, scorrevole senza guide a pavimento.

**Tipologia apertura 3:** Questa tipologia ha 1 anta B. Seguire l'istruzione come riportata

**Tipologia apertura 5:** Questa tipologia ha 2 ante B. Ripetere i punti 28 e 29 per 2 volte

**Tipologia apertura 7:** Questa tipologia ha 3 ante B. Ripetere i punti 28 e 29 per 3 volte

**Tipologia apertura 9:** Questa tipologia ha 4 ante B. Ripetere i punti 28 e 29 per 4 volte

## distinta

### Per tutte le aperture:

- 2 maniglie.
- 4 tappi copri vite per maniglie.
- 6 tappi copri foro.
- 1 piastrina pavimento.
- 4 viti autoforanti con impronta a croce 3,9x32, Zincate.

### Apertura 3:

- 1 Binario con compensatore.
- 2 battute laterali con compensatore.
- 1 anta con calamita e finta calamita.
- 2 ante con finta calamita e spazzolino.
- 1 anta con calamita e spazzolino.
- 6 blocchetti antibloccaggio.

### Apertura 5:

- 2 Binari con compensatore.
- 4 battute laterali con compensatore.
- 1 anta con calamita e finta calamita.
- 2 ante con finta calamita e spazzolino.
- 1 anta con calamita e spazzolino.
- 8 blocchetti antibloccaggio.

### Apertura 7:

- 2 Binari con compensatore.
- 4 battute laterali con compensatore.
- 1 anta con calamita e finta calamita.
- 3 ante con finta calamita e spazzolino.
- 1 anta con calamita e spazzolino.
- 10 blocchetti antibloccaggio.

### Apertura 9:

- 2 Binari con compensatore.
- 4 battute laterali con compensatore.
- 1 anta con calamita e finta calamita.
- 4 ante con finta calamita e spazzolino.
- 1 anta con calamita e spazzolino.
- 12 blocchetti antibloccaggio.

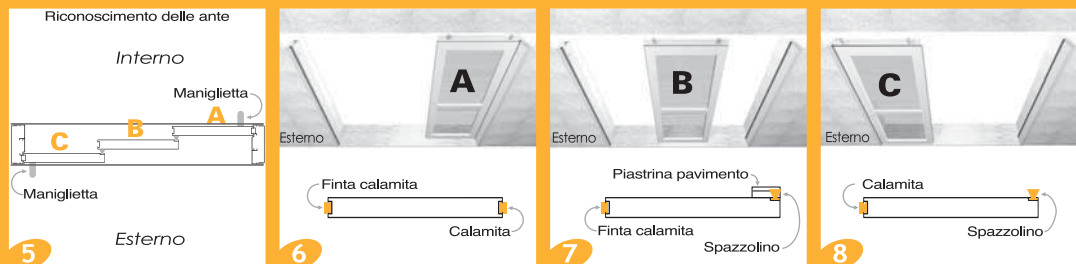
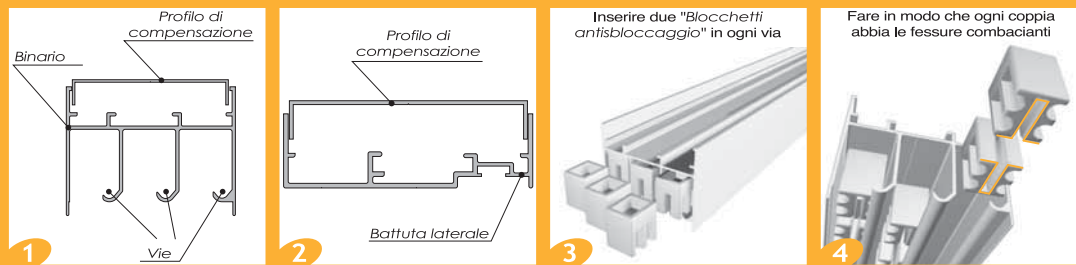

Forare e avvitare. **1**



Separare gli *antibloccaggio* in modo che possano ospitare nel mezzo un'anta

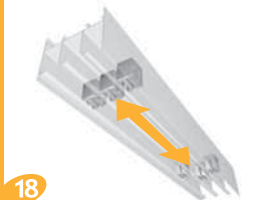

Inserire l'anta C nella via esterna del Binario



Inserire la *Piastrina pavimento*

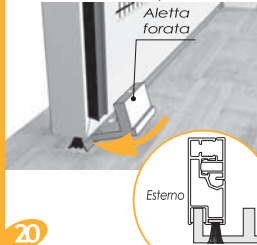

Agganciare l'anta al magnete della *Battuta laterale*



Far scivolare la *Piastrina pavimento* fino alla fine dell'anta



Segnare il punto per il foro



Forare. **2**



Avvitare. **2**



Allentare i *Grani compensatori* per facilitare l'aggancio dell'anta B



Alzare leggermente l'anta per inserirla nella *Piastrina pavimento*



Inserire l'anta B nella via centrale



Alzare leggermente l'anta per inserirla nella *Piastrina pavimento* fissata a terra



Applicare le due maniglie nell'anta A verso il magnete come da disegno 5

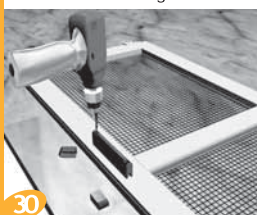

Inserire l'anta A nella via interna



Alzare leggermente l'anta per inserirla nella *Piastrina pavimento* fissata sull'anta B



Regolare i *Grani compensatori* fino a che ogni anta abbia lo spazzolino appoggiato a terra

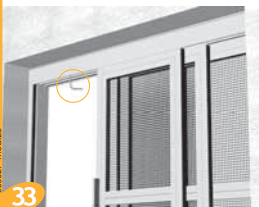

Forare. **1**



Avvitare. **1**



Inserire gli *antibloccaggio* nell'aletta superiore delle ante



# Istruzioni di montaggio per zanzariera, scorrevole senza guide a pavimento.

**Tipologia apertura 4 :** Questa tipologia ha 1 anta B. Seguire l'istruzione come riportata

**Tipologia apertura 6 :** Questa tipologia ha 2 ante B. Ripetere i punti 28 e 29 per 2 volte

**Tipologia apertura 8 :** Questa tipologia ha 3 ante B. Ripetere i punti 28 e 29 per 3 volte

**Tipologia apertura 10 :** Questa tipologia ha 4 ante B. Ripetere i punti 28 e 29 per 4 volte

## distinta

### Per tutte le aperture :

- 2 maniglie.
- 4 tappi copri vite per maniglie.
- 6 tappi copri foro.
- 1 piastrina pavimento.
- 1 viti autoforanti con impronta a croce 3,9x32, Zincate.

### Apertura 4 :

- 1 Binario con compensatore.
- 2 battute laterali con compensatore.
- 1 anta con calamita e finta calamita.
- 1 anta con finta calamita e spazzolino.
- 1 anta con calamita e spazzolino.
- 6 blocchetti antibloccaggio.

### Apertura 6 :

- 2 Binari con compensatore.
- 4 battute laterali con compensatore.
- 1 anta con calamita e finta calamita.
- 2 ante con finta calamita e spazzolino.
- 1 anta con calamita e spazzolino.
- 8 blocchetti antibloccaggio.

### Apertura 8 :

- 2 Binari con compensatore.
- 4 battute laterali con compensatore.
- 1 anta con calamita e finta calamita.
- 3 ante con finta calamita e spazzolino.
- 1 anta con calamita e spazzolino.
- 10 blocchetti antibloccaggio.

### Apertura 10 :

- 2 Binari con compensatore.
- 4 battute laterali con compensatore.
- 1 anta con calamita e finta calamita.
- 4 ante con finta calamita e spazzolino.
- 1 anta con calamita e spazzolino.
- 12 blocchetti antibloccaggio.

<p>1</p>	<p>2</p>	<p>3</p> <p>Inserire due "Blocchetti antibloccaggio" in ogni via</p>	<p>4</p> <p>Fare in modo che ogni coppia abbia le fessure combacianti</p>
<p>5</p> <p>Riconoscimento delle ante</p>	<p>6</p> <p>Interno</p> <p>Esterno</p>	<p>7</p> <p>Esterno</p>	<p>8</p> <p>Esterno</p>
<p>9</p> <p>Accostare l'anta A e l'anta C alle battute laterali per verificare che le calamite si attraggano</p>	<p>10</p> <p>Nel caso in cui le calamite si respingano, sfilare e capovolgere il magnete dalla battuta laterale</p>	<p>11</p> <p>Posizionare il Binario nel vano</p> <p>Interno</p>	<p>12</p> <p>Alloggiamento Battute laterali</p>
<p>13</p> <p>Inserire le due battute laterali sui fianchi del foro finestra</p>	<p>14</p> <p>Assicurarsi che le Battute laterali si alloggino all'interno del Binario</p>	<p>15</p> <p>Avvitare i tre grani compensatori presenti nei fori predisposti sul Binario</p>	<p>16</p> <p>Avvitare fino ad ottenere una buona stabilità della struttura</p>



Forare e avvitare \*1



Separare gli *antibloccaggio* in modo che possano ospitare nel mezzo un'anta

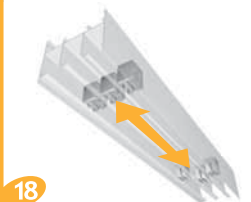

Inserire l'anta **C** nella *vía* esterna del *Binario*



Inserire la *Piastrina pavimento*

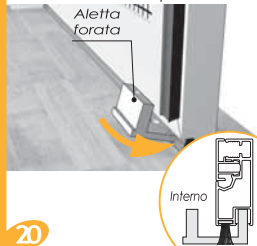

Agganciare l'anta al magnete della *Battuta laterale*



Far scivolare la *Piastrina pavimento* fino alla fine dell'anta



Segnare il punto per il foro



Forare \*2



21

22

23

24

Avvitare \*2



Allentare i *Grani compensatori* per facilitare l'aggancio dell'anta **B**



Alzare leggermente l'anta per inserirla nella *Piastrina pavimento*



Inserire l'anta **B** nella *vía* centrale



25

26

27

28

Alzare leggermente l'anta per inserirla nella *Piastrina pavimento* fissata a terra



Applicare le due maniglie nell'anta **A** verso il magnete come da disegno 5



Inserire l'anta **A** nella *vía* interna



Alzare leggermente l'anta per inserirla nella *Piastrina pavimento* fissata sull'anta **B**



29

30

31

32

Regolare i *Grani compensatori* fino a che ogni anta abbia lo spazzolino appoggiato a terra



Forare \*1



Avvitare \*1



Inserire gli *antibloccaggio* nell'alea superiore delle ante



33

34

35

36



# Istruzioni di montaggio per zanzariera, scorrevole senza guide a pavimento.

## Tipologia apertura 11 a 4 ante.

Istruzioni di montaggio  
**30**  
Istruzioni di montaggio

distinta

- 1 Binario con compensatore.
- 2 battute laterali con compensatore.
- 2 ante con calamita e finta calamita.
- 2 ante con calamita e spazzolino.
- 2 maniglie.
- 4 tappi copri vite per maniglie.
- 6 tappi copri foro.
- 2 piastrine pavimento.
- 8 blocchetti antisbloccaggio.
- 4 viti autoforanti con impronta a croce 3,9x32, Zincate.

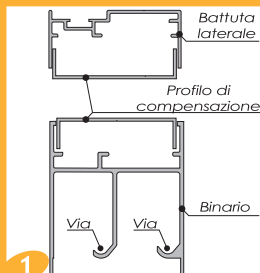

1



2



3

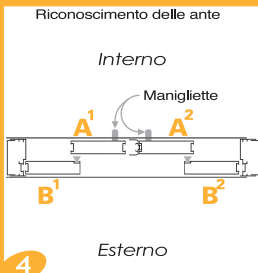

4

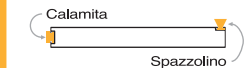

5

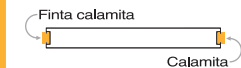
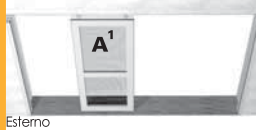

6

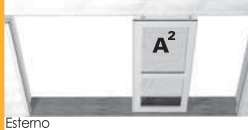

7



8

Applicare la maniglia nelle ante A<sup>1</sup> e A<sup>2</sup> come da disegno 5



9

Accostare le ante alle battute laterali per verificare che le calamite si attraggano



10

Nel caso in cui le calamite si respingano, sfilare e capovolgere il magnete dalla battuta laterale

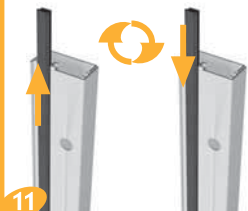

11

Prima di posizionare il Binario fare attenzione che sia rivolto come da disegno



12

Posizionare il Binario nel vano

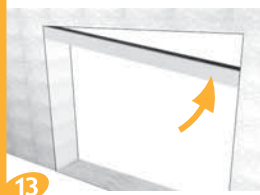

13

Allargamento Battute laterali

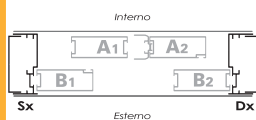

14

Inserire le due battute laterali sui fianchi del foro finestra. Assicurarsi che si alloggino all'interno del Binario



15

Avvitare i tre grani compensatori presenti nei fori predisposti sul Binario



16

Avvitare fino ad ottenere una buona stabilità della struttura



Forare e avvitare 1



Separare gli antibloccaggio in modo che possano ospitare nel mezzo un'anta



Inserire le ante B1 e B2 nella via esterna del Binario



21



22



23



24



Segnare il punto per il foro



Forare 2



Avvitare 2



Allentare i Grani compensatori



Alzare leggermente l'anta per inserirla nella Piastrina pavimento



Inserire le ante A1 e A2 nella via interna

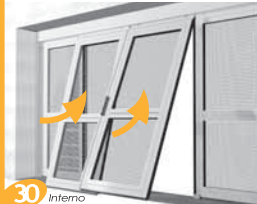

Alzare leggermente le ante per inserirle nelle Piastrine pavimento fissate a terra



Regolare i Grani compensatori fino a che ogni anta abbia lo spazzolino appoggiato a terra



Forare 1



Avvitare 1



Inserire due antibloccaggio per ogni anta, incastrandoli nell'aletta superiore



# Istruzioni di montaggio per zanzariera, scorrevole senza guide a pavimento.

## Tipologia apertura 12 a 6 ante.

Istruzioni di montaggio  
**31**  
Istruzioni di montaggio

distinta

- 1 Binario con compensatore.
- 2 battute laterali con compensatore.
- 2 ante con calamita e finta calamita.
- 2 ante con calamita e spazzolino.
- 2 ante con calamita e spazzolino.
- 2 ante con finta calamita e spazzolino.
- 2 maniglie.
- 4 tappi copri vite per maniglie.
- 6 tappi copri foro.
- 2 piastine pavimento.
- 12 blocchetti antibloccaggio.
- 4 viti autoforanti con impronta a croce 3,9x32, Zincate.

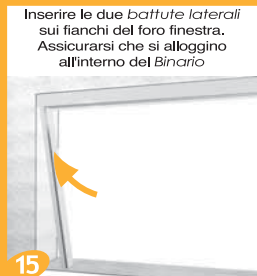
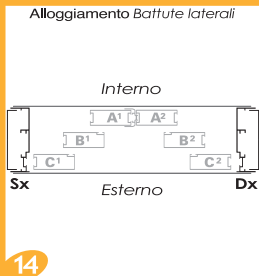
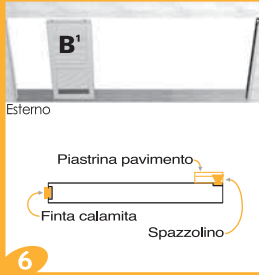
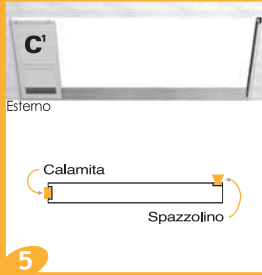
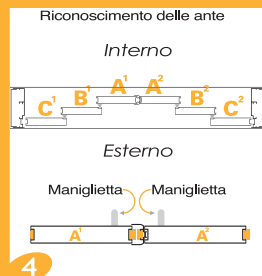
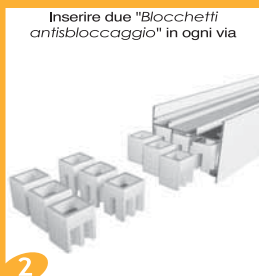
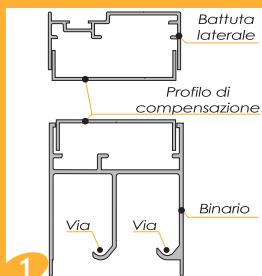



Forare e avvitare **1**



Separare gli antisbloccaggio in modo che possano ospitare nel mezzo un'anta



Inserire le ante C1 e C2 nella via esterna del Binario



Inserire la Piastrina pavimento



Agganciare l'anta al magnete della Battuta laterale



Far scivolare la Piastrina pavimento fino alla fine dell'anta



Segnare il punto per il foro



Forare **2**



Avvitare **2**



Allentare i Grani compensatori per facilitare l'aggancio delle ante



Alzare leggermente l'anta per inserirla nella Piastrina pavimento



Inserire le ante B1 e B2 nella via centrale



Alzare leggermente l'anta per inserirla nella Piastrina pavimento fissata a terra



Applicare la maniglia nelle ante A1 e A2 come da disegno 4



Inserire le ante A1 e A2 nella via interna



Alzare leggermente le ante per inserirle nelle Piastrine pavimento fissate nelle ante B1 e B2



Regolare i Grani compensatori fino a che ogni anta abbia lo spazzolino appoggiato a terra



Forare **1**



Avvitare **1**



Inserire gli antisbloccaggio nell'aletta superiore delle ante

